

X/5 Chrome-Moly Pedal Disassembly

Tools Needed: T-15 Torx Wrench, 9mm Socket and 15mm Open-end Wrench.

- Step 1. Remove the two body screws with a T-15 torx wrench.
- Step 2. Separate the two halves of the body.
- Step 3. Pull the alloy housing out of the body.
- Step 4. Pull off the luber cap.
- Step 5. Use a 9mm socket to remove the nut from the end of the spindle.
- Step 6. Slide the alloy housing and "O" ring off the spindle.
- Step 7. The cartridge bearing can now be carefully pushed out of the alloy housing from the opposite end.

Note: Do not try to remove the needle bearing from the alloy housing. The needle bearing is permanently pressed into the housing and cannot be removed without damaging components.

Lubrication and Reassembly

Use a high-quality, waterproof grease on the needle bearing and use a new "O" ring (grease it too) when overhauling X/5 Chrome-Moly Pedals. Any worn or damaged parts should be replaced. Reassembly is accomplished by reversing the order of the above instructions.

⚠ WARNING TIGHTEN NUT SECURELY (8.5 - 9.6 Nm / 75 - 85 inch pounds).

⚠ WARNING TIGHTEN T-15 BOWTIE SCREWS SECURELY (4.5 Nm / 40 inch pounds).

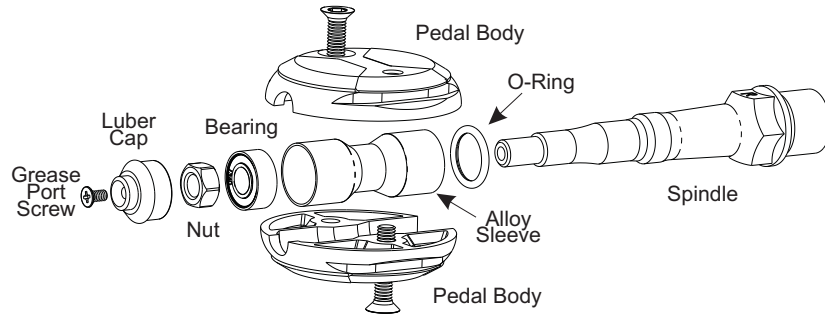

X/1 Titanium & X/2 Stainless Steel Pedal Disassembly

Tools Needed: T-20 Torx Key, Retainer clip pliers, 15mm open-end wrench.

- Step 1. Back out the Grease-Port Screw just enough to grip with pliers and pull to remove dust cap from body.
- Step 2. Remove the Torx Screw (T-20 size) from the end of the spindle. To ease removal of the Torx Screw, heat the screw with a soldering gun to 300°F to loosen the bond of the Loctite on the screw threads.
- Step 3. Pull the spindle out of the X Pedal body.
- Step 4. Using retainer clip pliers, remove the retainer clip from the groove in the bore of the X Pedal body.
- Step 5. Push the two cartridge bearings out the dust cap side of the X Pedal body. (Use the spindle with Torx Screw partially installed as a tool to carefully push the bearings out of the X Pedal body).

Note - Do not try to remove the needle bearing from the pedal body. The needle bearing is permanently bonded into the body and cannot be removed without damaging components.

Lubrication and Reassembly

Use a high-quality, waterproof grease on the needle bearing and use a new "O" ring (grease it too) when overhauling X Series Pedals. Any worn or damaged parts should be replaced. Reassembly is accomplished by reversing the order of the above instructions. **Be sure retainer clip is fully seated in bore groove and reapply Loctite to the Torx Screw threads when reassembling Pedal.**

⚠ WARNING TIGHTEN T-20 SPINDLE-END SCREW SECURELY (3.6 Nm / 32 inch pounds).

⚠ WARNING TIGHTEN T-15 BOWTIE SCREWS SECURELY (4.5 Nm / 40 inch pounds).

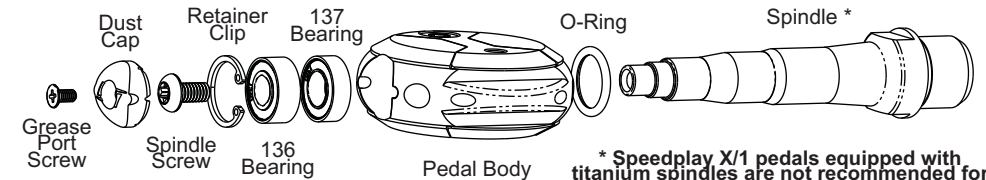

LIMITED (TWO YEAR) WARRANTY

This Speedplay product is warranted under normal usage against defects in workmanship and materials to the original purchaser for a period of two (2) years from the date of purchase free of charge provided the claim is made within thirty (30) days of the discovery of the defect and the following condition is met: The purchaser must obtain advance authorization by calling Speedplay at 800-468-6694 toll free or (858) 453-4707 before returning any product for warranty inspection. A Return Authorization (RA) number will be issued and must conspicuously appear on the outside of the product's packaging. The issuance of an RA number does not constitute acceptance of the claim. The determination of whether the claim is covered by this warranty is within the sole discretion of Speedplay, Inc. The part(s) requiring service or replacement must be returned to Speedplay, either by the purchaser or a Speedplay dealer. Insurance, handling and transportation charges for service shall be borne by the person desiring service. This warranty is limited to the repair or replacement of this product. Speedplay, at its option, will either repair or replace any defective parts.

For a warranty claim to be honored, the following information must accompany the returned product:

- a) A copy of the original dated receipt or other proof of retail purchase.
- b) A detailed description of the problem with the product along with the R.A. number.
- c) Identification of the shoe brand and model used in conjunction with the product.
- d) Estimate of product usage (in accumulated mileage).
- e) Your name, street address (no P.O. boxes) and phone number(s) where you may be reached.
- f) The product must be securely packaged and sent insured through a traceable shipper.

The repaired product or replacement will be returned to the purchaser or the Speedplay dealer usually within two weeks. Product furnished as replacement will continue to be covered under this warranty until two years after the date of original purchase.

Limits and exclusions: Not covered by warranty is damage resulting from normal wear and deterioration occurring from use, accidents, neglect, improper assembly, misuse, abuse, lack of reasonable or proper maintenance, corrosion, any damage resulting from causes other than defects in materials and workmanship; failure or loss by accident, alterations, repairs improperly performed, or replacement parts improperly installed, modifications not recommended or approved in writing by Speedplay, labor costs for removal, or compensation for inconvenience or loss of use while the product is being repaired or replaced. This warranty also does not cover cosmetic imperfections in the surface finish, or appearance of the product which were apparent or discoverable at the time of purchase, or damage during shipment of the product.

There are no warranties which extend beyond the face hereof. All warranties implied by state law, including the implied warranties of merchantability and fitness for a particular purpose, are expressly limited to the duration of the limited warranty set forth above. Some states do not allow limitations on how long an implied warranty lasts, so the above limitation may not apply to you. With the exception of any warranties implied by state law as hereby limited, the foregoing express limited warranty is exclusive and in lieu of all other warranties, guarantees, agreements and similar obligations of manufacturer or seller.

Speedplay is not liable for indirect or consequential damages in connection with the use of this product. Some states do not allow the exclusion or limitation of incidental or consequential damages, so the above limitation or exclusion may not apply to you.

No person, independent representative, agent, distributor, dealer (including any Speedplay dealer) or company is authorized to change, modify or extend the terms of this warranty in any manner whatsoever. This warranty gives you specific legal rights; you may also have other rights which vary from state to state.

IMPORTANT
 FAILURE TO FOLLOW THESE INSTRUCTIONS AND
 WARNING STATEMENTS BEFORE ASSEMBLING AND USING
 THIS SYSTEM MAY RESULT IN SERIOUS PERSONAL INJURY

SPEEDPLAY
X SERIES
PEDAL SYSTEMS
WITH X SERIES V2 CLEATS

HAND OVER INSTRUCTIONS TO CUSTOMER
 PLEASE VISIT WWW.SPEEDPLAY.COM FOR
 INSTRUCTIONS IN ADDITIONAL LANGUAGES.



SPEEDPLAY

10151 PACIFIC MESA BLVD., #107
 SAN DIEGO, CA 92121 (858) 453-4707
 1-800-468-6694 WWW.SPEEDPLAY.COM

GENERAL SAFETY INFORMATION

⚠WARNING TO AVOID SERIOUS INJURIES:

- Bicycle dealers -- be sure to give all instructions and warranty information to end customer.
- Speedplay X/1 pedals equipped with titanium spindles are not recommended for use by persons weighing over 185 pounds.
- Riding bicycles is an inherently dangerous activity. All bicycle parts, both new and used, must be inspected carefully before use, and riders must exercise judgment as to each part's safety. All bicycle components should be inspected for safety on a regular basis, preferably before each ride.
- Read all instructions carefully before using this product. Failure to follow these instructions and warning statements before assembling and using this system may result in severe injury. Improper mounting and/or use of this product can result in severe injury. Clipless Pedals are not for beginner riders.
- Speedplay X Series Pedals are not intended for off-road use. **X/5 pedals are recommended for recreational noncompetitive road riding only.**
- Speedplay Pedals are not equipped with reflectors and are not intended for nighttime or other reduced visibility riding conditions. Do not expect Speedplay Pedals to improve your chances of being seen in conditions of darkness or reduced visibility. Always use a proper headlight and tail light when riding at any time of reduced visibility.
- If you have any doubts about your ability to correctly install Speedplay Pedals or Cleats, or if you are unsure about the extent of wear to any Speedplay Pedal or Cleat part, please return it to your dealer for proper installation or inspection, or call Speedplay at 1-858-453-4707 (PST) or toll free at 1-800-468-6694 (PST). If you have any questions or concerns about issues such as shoe compatibility, operating the release mechanism, the intended use of the Pedals, or the maintenance of this product, call Speedplay toll free at 1-800-468-6694 (PST).
- The LEFT and RIGHT Cleats of X Series pedals are different. Be sure to install the Cleat marked "LEFT" on the LEFT shoe and the Cleat marked "RIGHT" on the RIGHT shoe. Before mounting Speedplay Cleats to any shoe, make sure that the brand and model of shoe selected is compatible with Speedplay Cleats. Not all shoes are compatible with Speedplay Cleats. Using Speedplay Cleats with shoes that are not compatible could cause the Pedal System to disengage unexpectedly and cause a fall that could result in severe injury. For the most current information on shoe compatibility, visit the **Speedplay Road Shoe Compatibility Guide** online at www.speedplay.com or contact Speedplay toll free at 1-800-468-6694 (PST).
- Be sure to use the correct length of Speedplay Cleat Mounting or Fastening Screws. Do not use Speedplay Cleat Mounting or Cleat Fastening screws that are too short to fully engage the threads of the corresponding fastener located in the shoe. If the screws are too short, the screws may not sufficiently engage the corresponding threads causing the Cleat to come off the shoe which can lead to a fall that can result in severe injury. **ONLY use Speedplay mounting hardware with Speedplay Cleats.**
- Do not use the Snap-Shim Cleat mounting screws with any previous models of Speedplay X Cleats including the Slim Line Cleat. The Snap-Shim Cleat mounting screw heads are too small and may pull through the older base plates. This may cause the cleat to pull off the shoe causing a fall that may result in severe injury.
- Always tighten the threaded screws or nuts on the Pedals and Cleats to the recommended torque settings for each part. See instructions for **Pedal Mounting** and **Steps for Attaching X Series V.2 Cleats to the Shoes**. Over-tightening a threaded part may cause serious damage to the part or prevent it from working properly. Under-tightening threaded parts can cause a part to become loose and fall out. Either under-tightening or over-tightening a threaded part can lead to a fall that can result in severe injury. Over-tightening Speedplay Cleat Fastening screws prevents the springs from operating properly, can affect engagement and retention, and can cause the springs to break, which can lead to a fall that can result in severe injury.
- Speedplay X Series Pedals and Cleats require routine lubrication and cleaning to prevent serious injury while riding. See **Instructions for Routine X Series V.2 Cleat Maintenance and Routine X Series Pedal Bearing Lubrication**. Keep all Pedal and Cleat parts clean of debris and properly lubricated in order to ensure proper engagement and release. Speedplay X Series Pedals require the Cleat springs to be lubricated routinely with a dry-type lubricant. X Series Pedals and Cleats wear out over time and must be replaced. **Never install cleats using any combination of new cleat parts and old cleat parts.** When replacing cleats, replace **all** used parts with new V.2 parts. To prevent serious injury while riding, be sure your entire bicycle is adequately maintained and that all components are correctly installed and adjusted.
- **Never** ride with Speedplay Pedals or Cleats that are improperly installed, modified or excessively worn. Remember to check the Cleats and Pedals periodically for wear. When parts exhibit noticeable "play" or are visibly worn, replace them immediately. **Never install cleats using any combination of new cleat parts and old cleat parts.** When replacing cleats, replace **all** used parts with new V.2 parts. A loose, over-tightened, damaged, unlubricated, or worn part may cause the Pedal System to disengage unexpectedly and cause a fall that could result in severe injury.
- Before your first ride with these Pedals, all riders should engage and disengage each Pedal with one foot on the ground on a level, safe place until you are adept and comfortable with all operations of the Speedplay X Series Pedal System. Whenever you ride at slow speed or whenever you are stopping, release your shoes from your Pedals beforehand so that you can quickly place your foot on the ground at any time. Speedplay Pedals are not designed to release automatically at times such as when falling off the bicycle. This is a safety measure to prevent you from losing balance and falling off the bicycle as a result of your feet becoming accidentally released from the Pedals.
- **Do not attempt to engage Speedplay X Series V.2 Cleats onto Speedplay Light Action Pedals or Zero Pedals. Speedplay X Series V.2 Cleats and Pedal Systems are not designed to be compatible with Speedplay Light Action Pedals or Zero Pedals. Use only X Series V.2 Cleats with X Series Pedals.** Any effort to engage or use X Series Pedals and cleats with any other Speedplay Pedal System may cause permanent damage to the Pedals or severe injury.
- Failure to follow these warning statements and instructions before assembling and using this Pedal System may result in severe injury.

BASIC OPERATION

Speedplay X Series Pedals are dual sided for convenient entry. The safest way to engage the pedals is to keep one foot on the ground, place your other foot on the pedal with the ball of your foot flat and push downward. Lowering your heel and adding a bit of a twist to the downward push aids entry. **No toe-in or heel-in technique is required.** It makes no difference what position the pedal is in when you step down on it because X Series pedals are "self-locating" and "self-righting". Pedal release is accomplished by turning your heel outward while lifting upward. X Series Pedals are not designed to release automatically at times such as when falling off the bicycle. **See WARNINGS under GENERAL SAFETY INFORMATION.**

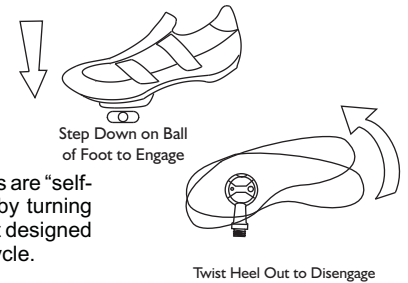

Pedal Mounting Instructions

Mount the Pedals to the bicycle crankarms. Use a 15mm open-ended wrench to mount the Pedals on the crankarms. The right Pedal has right-hand threads and the left Pedal has left-hand threads. Minimum tightening torque = 28.2 Nm / 250 inch pounds.

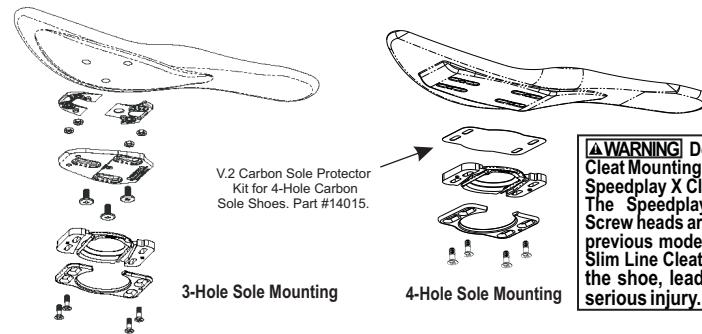

⚠WARNING Do NOT use Speedplay Snap Shim Cleat Mounting Screws with any previous model Speedplay X Cleats, including Slim Line Cleats. The Speedplay Snap Shim Cleat Mounting Screw heads are too small and may pull through previous model X Cleat Base Plates, including Slim Line Cleats, causing the Cleat to come off the shoe, leading to a fall that can result in serious injury.

Cleat Mounting with Version 2 (V.2) Cleat Black Base Plate

The X Series V.2 Cleat consists of three layers and is designed to fit shoes with a 3-hole mounting pattern and a curved sole. Shoes with a 3-hole pattern use all three layers of the Speedplay X Series V.2 Cleat (V.2 Black Base Plate with factory-installed set of Blue 5-F and 5-R Snap Shims, Black Spring Housing and Gold Metal Bottom Plate). X Series V.2 Cleats also fit shoes with a flat, 4-hole pattern. Shoes with a 4-hole pattern use only the two outer layers (Black Spring Housing and Gold Metal Bottom Plate) of the Speedplay X Series V.2 Cleat. **See STEPS FOR ATTACHING X SERIES V.2 CLEATS TO THE SHOES.**

Ensure Cleat to Shoe Compatibility Prior to Installation

Shoes with a 3-Hole pattern require all three layers of the Speedplay X Series V.2 Cleat (V.2 Black Base Plate with factory-installed Blue 5-F and 5-R set of Snap Shims, Black Spring Housing and Gold Metal Bottom Plate). The Speedplay X Series V.2 Cleat includes a second set of Snap Shims, 6-F and 6-R Snap Shims, in the package. Your choice of Snap Shims will depend on the radius of the curvature of the shoe sole. The Snap Shims, which can easily be removed from and installed on the V.2 Black Base Plate, must closely match the curvature of the shoe sole. With Snap Shims mounted, the side of the V.2 Base Plate with the Snap Shims will have a curved profile and the opposite side will be flat. The curved side of the V.2 Base Plate mounts against the curved shoe sole. **The shoe sole must have a continuous curvature (radius) and be flat from side-to-side at the Cleat-contact area to closely match the contour of the V.2 Base Plate.** Use the set of two (2) Blue 6-F and Blue 6-R Snap Shims if the shoe sole radius is too small to conform to the factory-installed standard Blue 5-F and Blue 5-R Snap Shims. If the curved side of the V.2 Base Plate with either set of Snap Shims installed does not closely match the curvature of your shoe sole, please call Speedplay, toll free, for technical assistance at 1-800-468-6694 (PST). Speedplay X Series V.2 Cleats that are mounted against 3-hole curved shoe soles with a radius that is too large or too small will bow the Cleat either inward or outward and the Cleat will not function properly. **See WARNINGS under GENERAL SAFETY INFORMATION.**

If you have any questions or concerns about 1) shoe compatibility, 2) the proper installation of the Speedplay X Series V.2 Cleat parts on your shoes, or 3) if the curved side of the V.2 Base Plate with either set of Snap Shims installed does not closely match the curvature of your shoe sole, call Speedplay for technical assistance toll free at 1-800-468-6694 (PST).

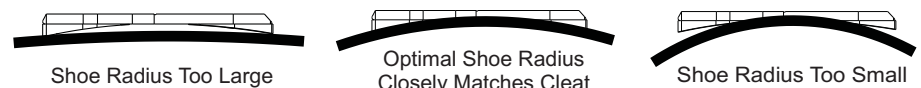

CHECKLIST OF X SERIES V.2 CLEAT PARTS

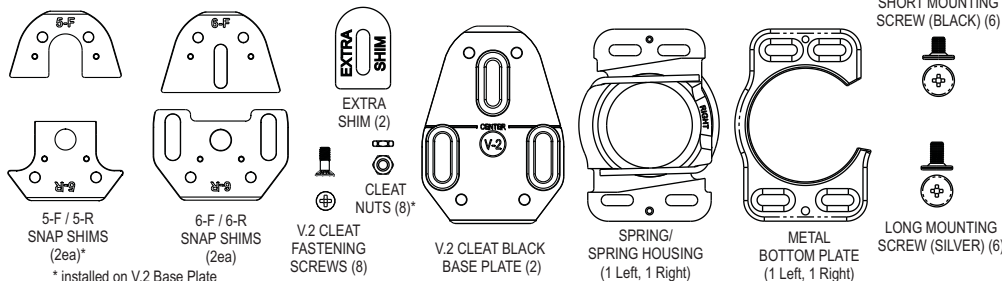

Steps For Attaching X Series V.2 Cleats To The Shoes: Using Shoes with 3-Hole Mounting Pattern

⚠ WARNING Use only V.2 Cleat Fastening Screws supplied with V.2 Cleats. Do NOT use previous versions of Cleat Fastening Screws with the V.2 Cleats. All previous versions of Cleat Fastening Screws are too short for use with V.2 Cleats and can affect the engagement and retention of the pedal system which can lead to a fall that can result in severe injury. **Never install cleats using any combination of new cleat parts and old cleat parts.** When replacing cleats, replace all used parts with new V.2 parts.

1. Select the LEFT cleat for the LEFT shoe and the RIGHT cleat for the RIGHT shoe. Determine which set of Snap Shims is required for your shoes (set of 5-F and 5-R or set of 6-F and 6-R). For the most current information on shoe compatibility, visit the [Speedplay Road Shoe Compatibility Guide](http://www.speedplay.com) online at www.speedplay.com or contact Speedplay toll free at 1-800-468-6694 (PST). The Snap Shims are removable, curved, blue plastic shims that snap onto the forward and rear ends of the underside of each V.2 Black Base Plate. The Snap Shims allow the flat V.2 Base Plate to closely match the curvature of the sole of most shoe brands. Remember, the shoe sole must have a continuous curvature (radius) and be flat from side-to-side at the Cleat-contact area to closely match the contour of the V.2 Base Plate. The 5-F & 5-R Snap Shims are factory-installed on the V.2 Base Plate. If your shoes require the two 6-F and two 6-R Snap Shims, first remove the two 5-F and two 5-R Snap Shims by carefully prying them off each V.2 Base Plate, then install the two 6-F and two 6-R Snap Shims. Be sure not to lose the four (4) nuts housed underneath the Snap Shims on each V.2 Base Plate when exchanging one set of Snap Shims for another.

2. Select the proper length 5mm flathead Cleat Mounting Screws (6) to attach the V.2 Cleat Base Plate to the shoe sole. (Black = short screws; Silver = long screws.) The correct length of the 5mm Mounting Screws must have a minimum of five (5) full turns of thread engagement in the shoe sole. Use only the Speedplay 5mm Mounting Screws provided with the Pedals as other screws will not work and may cause damage to the Cleats and Pedals.

⚠ WARNING You must make sure to choose the proper length Speedplay 5mm Mounting Screws suited for your brand and model of shoe. If the Speedplay 5mm Mounting Screws selected are too short to sufficiently engage the threads in the sole of your shoe, the X Series V.2 Cleat may pull away from the shoe unexpectedly, causing a fall that could result in severe injury. If the Speedplay 5mm Mounting Screws selected are too long for your shoe sole, the screws may protrude through the threaded inserts in the sole and up into the foot bed of the shoe, causing discomfort when riding.

⚠ WARNING Do not use the Speedplay Snap Shim Cleat Mounting Screws with any previous models of Speedplay X Cleats including the Slim Line Cleat. The Speedplay Snap Shim Cleat Mounting Screw heads are too small and may pull through the older base plates. This may cause the cleat to pull off the shoe causing a fall that may result in severe injury.

⚠ WARNING **Never install cleats using any combination of new cleat parts and old cleat parts.** When replacing cleats, replace all used parts with new V.2 parts.

3. Place an X Series V.2 Cleat Base Plate on the sole of the LEFT shoe and an X Series V.2 Cleat Base Plate on the sole of the RIGHT shoe. The slots in each V.2 Base Plate allow front-to-back Cleat adjustment.

4. Position each X Series V.2 Cleat Base Plate centerline scribe mark over the ball of the foot or where personal preference dictates. Insert the correct length Speedplay 5mm Cleat Mounting Screws (see 2. above) and tighten the three (3) screws on each V.2 Base Plate securely with a #2 Phillips screwdriver. **NOTE:** If a greater range of either forward or rearward adjustment is needed, use the Speedplay Cleat Extender Base Plate Kit (Part #13330 sold separately) in place of the standard X Series V.2 Cleat Base Plate.

⚠ WARNING Do NOT over-tighten -- Maximum Mounting Screw Torque is 4.0 Nm / 35 inch pounds. Over tightening the 5mm Mounting Screws may cause damage to the X Series V.2 Base Plate. See WARNINGS under GENERAL SAFETY INFORMATION.

⚠ CAUTION IMPROPERLY MOUNTED X SERIES V.2 CLEAT BASE PLATE

The X Series V.2 Cleat Base Plate is improperly mounted on the shoe when using the factory-installed 5-F and 5-R Snap Shims if:

a) **The outer flat surface of the V.2 Base Plate is bowed outward:**

If the V.2 Base Plate is **bowed outward in the center**, use the 6-F and 6-R set of Snap Shims, which is designed to fit a smaller radius sole curvature. Before installing the 6-F and 6-R Snap Shims, be sure to remove the original factory mounted 5-F and 5-R Snap Shims from the V.2 Base Plate. **NOTE:** If the V.2 Base Plate continues to bow outward in the center when using the 6-F and 6-R Snap Shims, install the supplied EXTRA SHIM between the front 6-F Snap Shim and the shoe sole, and under the front mounting screw to further reduce the radius of the X Series V.2 Cleat.

b) **The outer flat surface of the V.2 Base Plate is bowed inward:**

If the V.2 Base Plate is **bowed inward in the center**, call Speedplay technical assistance toll free at 1-800-468-6694 (PST).

c) **The V.2 Base Plate has a twist from front to back:**

If the V.2 Base Plate is **twisted** when mounted, the supplied EXTRA SHIM must be installed between the shoe sole and the V.2 Base Plate. Place the EXTRA SHIM under the appropriate rear mounting screw to raise the low side of the V.2 Base Plate to make it flat.

⚠ CAUTION The flat surfaces of the X Series V.2 Cleat Spring Housing (Black) and Metal Bottom Plate (Gold) must fit flat against each other and against the V.2 Black Base Plate when fitted together as an assembly and installed for the X Series Pedal System to engage securely and release properly.

5. The X Series V.2 Cleat Spring Housing (Black) and Metal Bottom Plates (Gold) snap together to form an assembly. Make sure the small locator pins protruding out of each Black Spring Housing fit properly into the corresponding alignment holes in each Gold Metal Bottom Plate. The word "LEFT" on the LEFT Spring Housing should be visible after the LEFT Metal Bottom Plate has been correctly placed on the LEFT Spring Housing. The word "RIGHT" on the RIGHT Spring Housing should be visible after the RIGHT Metal Bottom Plate has been correctly placed on the RIGHT Spring Housing. Once each Spring Housing and Metal Bottom Plate are fitted together, place the Spring Housing and Metal Bottom Plate assembly marked "LEFT" on the V.2 Base Plate installed on the LEFT shoe and place the Spring Housing and Metal Bottom Plate assembly marked "RIGHT" on the V.2 Base Plate installed on the RIGHT shoe.

6. Thread, but do not fully tighten, the four (4) V.2 4x12mm Cleat Fastening Screws through the slots in the Metal Bottom Plate and Spring Housing assembly on the LEFT shoe and into the threaded holes in the V.2 Black Base Plate on the LEFT shoe. Repeat for the RIGHT shoe.

7. Side-to-side X Series V.2 Cleat adjustment - Once the LEFT Spring Housing and LEFT Metal Bottom Plate assembly are fastened to the V.2 Base Plate installed on the LEFT shoe, engage the shoe with the LEFT cleat assembly onto the LEFT Speedplay X Series Pedal installed on your bicycle. Adjust the LEFT Spring Housing and Metal Bottom Plate of the Cleat assembly from side-to-side to provide adequate clearance between the toe box and the heel of the LEFT shoe and the crankarm of the bicycle. The toe box of the shoe should clear the crankarm when releasing from the pedal. The heel of the shoe should be clear of the crankarm during the pedal stroke. Repeat for the RIGHT shoe. If the toe box or heel of your shoe does not clear the crankarm of your bicycle, contact Speedplay for technical assistance toll free at 1-800-468-6694 (PST).

8. After side-to-side positioning of the LEFT X Series V.2 Cleat has been determined, thread the (4) V.2 4x12mm Cleat Fastening Screws with a #2 Phillips screwdriver into the Metal Bottom Plate. Tighten to 2.5 Nm / 22 inch pounds. **If you do not have a torque wrench to tighten to Nm or inch pounds,** then tighten the slack out of each screw with a #2 Phillips screwdriver until you feel a noticeable pre-load resistance (notching) from the detents under the screw head biting into the alloy material of the Metal Bottom Plate. After noticeable detent resistance is felt, tighten each screw no more than 1/4 turn (90 degrees). Repeat with the RIGHT shoe.

⚠ WARNING The Maximum Fastening Screw Torque = 2.5 Nm / 22 inch pounds. Do NOT over tighten X Series V.2 Cleat Fastening Screws. See WARNINGS under GENERAL SAFETY INFORMATION. Fastening screws must be sufficiently tightened to securely hold the cleat in place and prevent the screws from loosening over time. Do NOT over-tighten the X Series V.2 Cleat Fastening Screws.

⚠ WARNING IF THE X SERIES V.2 CLEAT 4x12mm FASTENING SCREWS ARE OVER-TIGHTENED, THE CLEAT SPRINGS MAY BIND IN THE CLEAT AND NOT ENGAGE THE GROOVES IN THE PEDALS CORRECTLY, AND INADVERTENT RELEASE MAY OCCUR CAUSING A FALL THAT COULD RESULT IN SEVERE INJURY. See WARNINGS under GENERAL SAFETY INFORMATION.

⚠ WARNING Before your first ride with the X Series Pedal System, separately engage the LEFT shoe with Cleat onto the LEFT Pedal and the RIGHT shoe with Cleat onto the RIGHT Pedal. When the X Series V.2 Cleats are mounted correctly, the X Series Pedal should float in the X Series V.2 Cleat with little resistance and should emit a crisp, audible snap when the cleat springs engage the grooves of the pedals. **SPEEDPLAY X SERIES V.2 CLEATS MUST BE PROPERLY MOUNTED OR INADVERTENT RELEASE MAY OCCUR CAUSING A FALL THAT COULD RESULT IN SEVERE INJURY.**

Using Shoes with 4-Hole Mounting Pattern

1. Plastic shoe soles with a 4-Hole pattern eliminate the need for the standard X Series V.2 Cleat Black Base Plate. For shoes with a 4-Hole pattern, the LEFT and RIGHT Spring Housings (Black) fit directly against the shoe sole.

CAUTION Carbon Fiber Shoe Soles with a 4-Hole pattern - These shoes require the Speedplay V.2 Carbon Sole Protector Kit (Part # 14015 sold separately) to be installed between the Black Spring Housing and the carbon fiber shoe sole. If the Carbon Sole Protector Shim is not used, serious wear damage to the carbon fiber shoe sole and the X Series V.2 Cleat will result. (Shoe soles made of plastic do not require the Carbon Sole Protector Shim).

2. The X Series V.2 Cleat Spring Housings (Black) and Metal Bottom Plates (Gold) snap together to form an assembly. Make sure the small locator pins protruding out of each Spring Housing properly fit into the corresponding alignment holes in each Metal Bottom Plate. The word "LEFT" on the LEFT Spring Housing should be visible after the LEFT Metal Bottom Plate has been correctly placed on the LEFT Spring Housing. The word "RIGHT" on the RIGHT Spring Housing should be visible after the RIGHT Metal Bottom Plate has been correctly placed on the RIGHT Spring Housing. Once each Spring Housing and Metal Bottom Plate are fitted together to form an assembly, place the Spring Housing and Metal Bottom Plate assembly marked "LEFT" directly against the plastic shoe sole of the LEFT shoe and place the Spring Housing and Metal Bottom Plate assembly marked "RIGHT" directly against the plastic shoe sole of the RIGHT shoe. **Remember, for shoes with carbon fiber soles, you MUST use the Speedplay V.2 Carbon Sole Protector Kit (Part #14015 sold separately). See 1. above.**

3. Thread, but do not fully tighten, the four (4) V.2 4x12mm Cleat Fastening Screws through the slots in the Metal Bottom Plate and Spring Housing and into the threaded holes in the LEFT shoe. The combined Spring Housing and Metal Bottom Plate provide side-to-side adjustment of the Cleat. The correct length of the 4mm Fastening Screws must have a minimum of five (5) full turns of thread engagement in the shoe sole. Repeat for the RIGHT shoe.

WARNING If the threaded inserts in the shoe sole slots are recessed below the surface of the shoe sole, special longer Speedplay V.2 4x13mm Cleat Fastening Screws (Part # 14020 sold separately) or V.2 4x16mm Cleat Fastening Screws (Part #14030 sold separately) MAY be needed to provide adequate thread engagement, i.e. five (5) full turns. See WARNINGS under GENERAL SAFETY INFORMATION. If you have any questions or concerns about whether the X Series V.2 Cleat is properly installed on your shoes or which longer screw kit should be used, call Speedplay toll free at 1-800-468-6694 (PST).

4. Side-to-side X Series V.2 Cleat adjustment - Once the LEFT Spring Housing and LEFT Metal Bottom Plate assembly are fastened to the LEFT shoe sole, engage the shoe with the LEFT cleat assembly onto the LEFT Speedplay X Series Pedal installed on your bicycle. Adjust the LEFT Spring Housing and Metal Bottom Plate assembly from side-to-side to provide adequate clearance between the toe box and heel of the LEFT shoe and the crankarm of the bicycle. The heel of the shoe should be clear of the crankarm during the pedal stroke. Repeat for the RIGHT shoe. If the toe box or heel of your shoe does not clear the crankarm of your bicycle, call Speedplay for technical assistance toll free at 1-800-468-6694 (PST).

5. After side-to-side positioning of the LEFT X Series V.2 Cleat has been determined, thread the (4) V.2 4x12mm Cleat Fastening Screws [or longer screws if required, Part #14020 (V.2 4x13mm) or Part #14030 (V.2 4x16mm)] with a #2 phillips screwdriver into the Metal Bottom Plate. Tighten to 2.5 Nm / 22 inch pounds. **If you do not have a torque wrench to tighten to Nm or inch pounds,** then tighten the slack out of each screw with a #2 phillips screwdriver until you feel a noticeable pre-load resistance (notching) from the detents under the screw head biting into the alloy material of the Metal Bottom Plate. After noticeable detent resistance is felt, tighten each screw no more than 1/4 turn (90 degrees). Repeat with the RIGHT shoe.

WARNING Maximum Fastening Screw Torque = 2.5 Nm / 22 inch pounds. Do NOT over-tighten X Series V.2 Cleat Fastening Screws. See WARNINGS under GENERAL SAFETY INFORMATION. Fastening screws must be sufficiently tightened to securely hold the cleat in place and prevent the screws from loosening over time. Do NOT over-tighten the X Series V.2 Cleat Fastening Screws.

WARNING IF THE X SERIES V.2 CLEAT 4x12mm or LONGER FASTENING SCREWS ARE OVERTIGHTENED, THE CLEAT SPRINGS MAY BIND IN THE CLEAT AND NOT ENGAGE THE PEDALS CORRECTLY, AND INADVERTENT RELEASE MAY OCCUR CAUSING A FALL THAT COULD RESULT IN SEVERE INJURY. See WARNINGS under GENERAL SAFETY INFORMATION.

WARNING Before your first ride with the X Series Pedal System, separately engage the LEFT shoe with Cleat onto the LEFT Pedal and the RIGHT shoe with Cleat onto the RIGHT Pedal. When the X Series V.2 Cleats are mounted correctly, the X Series Pedal should float in the X Series V.2 Cleat with little resistance and should emit a crisp, audible snap when the cleat springs engage the grooves of the Pedals. SPEEDPLAY X SERIES V.2 CLEATS MUST BE PROPERLY MOUNTED OR INADVERTENT RELEASE MAY OCCUR CAUSING A FALL THAT COULD RESULT IN SEVERE INJURY.

Routine X Series V.2 Cleat Maintenance

X Series Pedals require the X Series V.2 Cleat springs and pedal engagement edges to be lubricated routinely with Speedplay SPLUBE (p/n 13800) or other dry-type (PTFE) lubricant preferably every one or two rides. Routine lubrication extends the life and is necessary for the performance of Speedplay Pedal Systems. **Wet lubricants (oil, WD-40 etc.) are not recommended** as they attract dirt which accelerates wear. Lack of lubrication (and/or over tightening) can prevent the springs from opening properly during engagement and can cause jammed springs to break over time.

NOTE: Damage as a result of lack of lubrication or improper installation is not covered by Speedplay's warranty policy.

WARNING If for any reason the X Series V.2 Cleat springs should become clogged with debris and do not open and close completely, the spring cavities must be cleaned thoroughly and re-lubricated before riding so that the springs can open and close properly. RIDING WITH CLEAT SPRINGS CLOGGED WITH DEBRIS COULD RESULT IN DIFFICULT ENGAGEMENT, DIFFICULT DISENGAGEMENT OR INADVERTENT RELEASE CAUSING A FALL THAT COULD RESULT IN SEVERE INJURY. Any part of the X Series V.2 Cleats or Pedals showing damage or noticeable wear should be replaced immediately. **Never install cleats using any combination of new cleat parts and old cleat parts.** When replacing cleats, replace **all** used parts with new V.2 parts. It is recommended that X Series V.2 Cleats be replaced at least every 3000-5000 miles of use or whenever the parts show visible wear. If you have any questions or concerns about the maintenance of X Series V.2 Cleats or whether your X Series V.2 Cleats should be replaced, call Speedplay toll free at 1-800-468-6694 (PST).

Routine X Series Pedal Bearing Lubrication

The precision bearings in Speedplay X Series Pedals require greasing from time to time.

NOTE: Speedplay X Series Pedals require service if they either spin without the slight resistance of the protective "O" ring or if any grinding sensation is detected.

NOTE: Always use a high quality WATERPROOF BEARING GREASE. Never use a liquid spray lubricant or oil on Speedplay Pedal bearings. Speedplay recommends that the X Series Pedal bearings be greased with a pump-type grease gun at least every 2000 miles or every three months. Pedals should always be lubricated immediately after riding in wet, rainy, or unusually dusty conditions. With sufficient grease present, the pedal should not spin freely. The pedal should always have a small amount of resistance as a result of grease. If the pedal rotates freely by more than one half turn, the pedal needs greasing.

NOTE: Damage due to the lack of lubrication is not covered by Speedplay's warranty policy. Speedplay Grease Guns and Grease are available from Speedplay retailers or call Speedplay at 1-800-468-6694 (PST).

Instructions for Quick and Easy Pedal Bearing Lubrication Using the Built-in Grease Port

Note: Do not try to remove the needle bearing from the alloy housing (X/5) or pedal body (X/1 or X/2). The needle bearing is permanently bonded into the alloy housing (X/5) or pedal body (X/1 or X/2) and cannot be removed without damaging components.

CAUTION Use Grease Only! Never use oil or spray lubes on bearings.

1. Remove the Grease-Port Screw with a #1 Phillips screw driver.
2. Insert needle-type grease injector gun into grease port hole.
3. Pump gun slowly while turning Pedal body slowly until clean grease is visible at spindle end of Pedal body.
4. Wipe off excess grease and reinstall Grease-Port Screw.

Note: Over-tightening the Grease-Port Screw may strip the threads of the dust cap.

NOTE: Damage due to the lack of lubrication is not covered by Speedplay's warranty policy. Speedplay recommends that the X Series Pedal bearings be greased with a pump-type grease gun at least every 2000 miles or every three months. Pedals should always be lubricated immediately after riding in wet, rainy, or unusually dusty conditions.

Speedplay Grease Guns (part #13175) and replacement 3oz. Grease Tube (part #13560) are available from Speedplay retailers or call Speedplay at 1-800-468-6694 (PST).

Speedplay Pedal Systems are high performance products. Like all high performance products, Speedplay pedal systems require care and maintenance. For a long life and to keep the system functioning as designed, maintain the pedals and cleats as recommended.

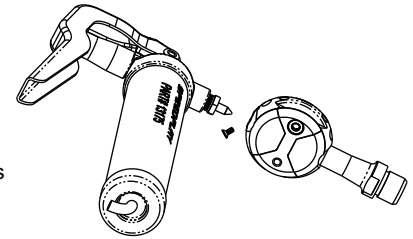

Leg-Length Discrepancy?

The Speedplay V.2 Leg-Length Shim Kits (part #14040 sold separately) can be used to shim the X Series V.2 Cleat in 1/3 cm (~1/8 inch) increments to correct leg length discrepancies. Call Speedplay for technical assistance toll free at 1-800-468-6694 (PST).